



SRX R

Remediation Pumps

Simply Reliable

SRX R

The SRX pump is based on a simple, innovative design and built with field-proven components. The result: a reliable pump to meet the demands of your remediation site.

Application

The SRX is an air-powered pump used to extract ground water or total fluids at variable rates equal to the well recharge rates. The SRX is available in two sizes, 1.75 in OD or 3.5 in OD for use in 2-in and 4-in wells respectively. Pump flow rates are up to 9.5 gpm. The SRX pump is available in a top-loading configuration for recovering total fluids or a bottom-loading model with higher pumping rates for dissolved phase.

Better Value

- More Uptime:
 - Reliable
 - Simple Routine Maintenance
- Competitive Price
- Fewer Parts

Our 25 years of experience with pneumatic pumps has produced the SRX. We used proven components to build a product that is simple and has fewer parts. The result? Reliability and effortless maintenance. It is so simple that, in minutes, the complete pump (including air, exhaust and fluid discharge check valves) can be disassembled with only one wrench.

Advantages

1. Advanced, positive-sealing air valves with built-in filtration.
2. Complete field disassembly with only one wrench.
3. Constructed with durable materials such as stainless steel, brass, Buna-N®, Nylon® and Viton®.
4. Durable Ebonite float.
5. Light weight.

Operation

The SRX is installed to the desired drawdown level. It requires only three lines: air supply, air exhaust and fluid discharge. Compressed air is supplied to the pump (generally 0.5 psi per foot of depth is sufficient). As the liquid enters the pump, the internal float moves to the upper (or "ON") position. At that end point, the float opens the air valve. Air enters the pump, closes the bottom inlet check valve (on bottom-loading versions), and pushes the fluid (in the pump chamber) through the center discharge tube and all the way to the surface. As the fluid is expelled from the vessel, the float returns to the lower limit (or "OFF" position) at which point it closes the air inlet valve and opens the air exhaust valve. As the pump fills under the fluid's own static pressure, air is vented through the exhaust port and the cycle is automatically repeated based on the well recharge rate.

Loading Configurations

Top-loading (SRX-R TL) pumps are selected for pumping total fluids (LNAPL and ground water simultaneously). Water table drawdown will be maintained at a level corresponding to the top inlet of the pump. Pumps of shorter lengths are available for lower drawdown requirements.

Bottom-loading pumps (SRX-R BL) are selected for dissolved phase or DNAPL applications. When installing the pump, the head is positioned at a depth of approximately 10 inches higher than the desired water table depression.



Top view of TR-974 and TR-978 top-loading pumps.



Top-loading pump, TR-974, disassembled.

Simply Reliable

Air Valve Design — The advanced air valve design provides a leak-tight seal. This is accomplished with a special Viton® ball ① on a stainless steel seat ②. The positive seal eliminates air leakage that can increase the formation of precipitates at the pump head. Assisted by an isolated magnet, the valve shifts positively, — every time. This prevents stalling even in slow-filling situations. No adjustments are necessary with this valve assembly.

Air Valve Filtration — The air valve incorporates 330-mesh stainless steel screens ③ to prevent debris from entering the ball/seat sealing assembly, possibly causing the valve to malfunction. On other pumps, when the air supply to the pump is turned off, the float will activate the air valve and create a pathway through which debris may enter the air valve and interfere with the proper seating of the ball. This is not a concern with the SRX pump. Please note that the 1.75 inch pump only has an air inlet filter assembly.

Easy Access — To make routine maintenance easier, the air and exhaust valves on the SRX can be accessed from the top of the pump by removing the air and exhaust hose barbs, eliminating the need to disassemble the pump body.

Lightweight Control Rod — The lightweight control rod ④ is a primary reason why the SRX does not stall. Less weight translates into less force that is required to open the air valve. This ensures a quick, positive opening every time. The control rod is isolated from the energy that is created by the float movement ⑤, thereby eliminating any stress on the rod.

Pump Disassembly — The SRX pump is designed to be completely disassembled with just one wrench. Remove the bolts from the bottom assembly, slide the body off and remove two cotter pins to access the control rod and float. Simple!

Screen Inlet — For cleaning bottom-loading pumps, the screen is easily removed by unthreading a single bolt. To protect the screen from collapse, the screen assembly is supported by an arch ⑥ at the bottom of the pump. A threaded inlet screen ⑦ is standard on all top-loading pumps to prevent debris from entering through the top inlet.

4-inch Top-loading pump

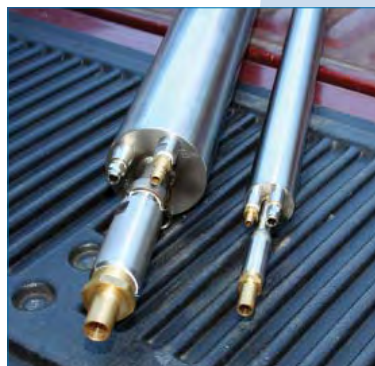
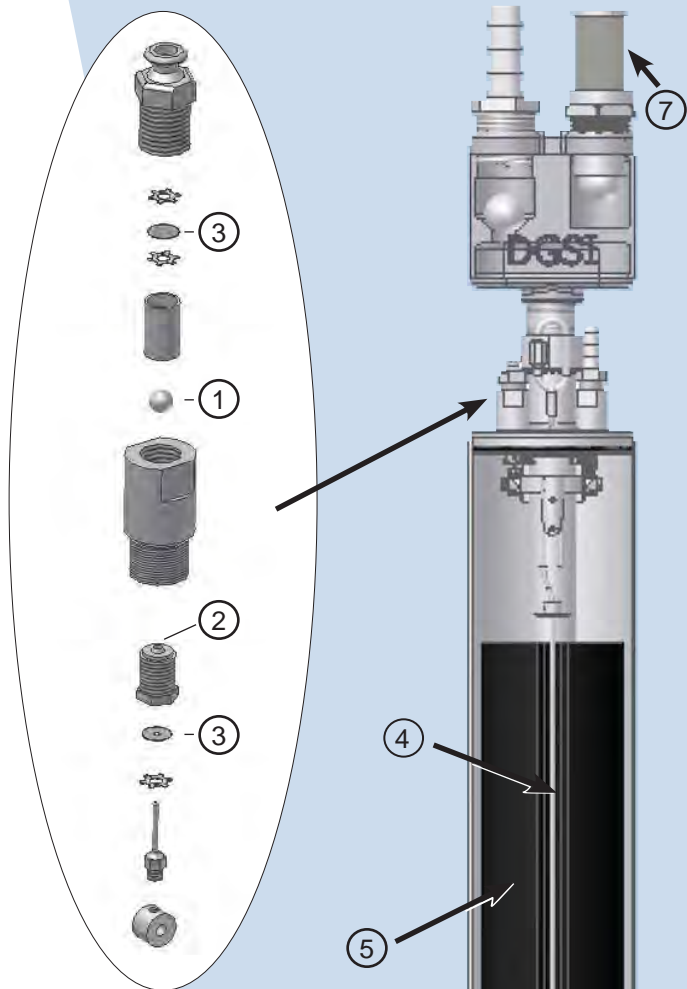

Top view of TR-975 and TR-977 bottom-loading pumps

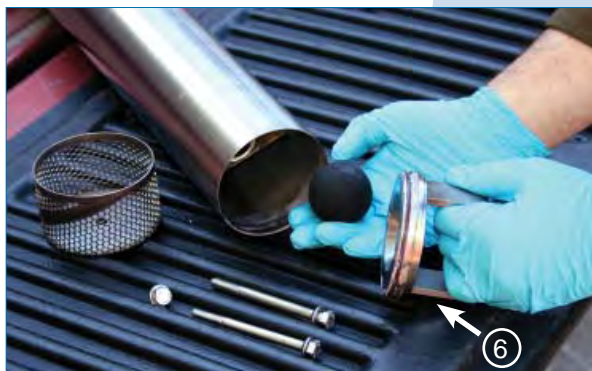

Bottom-loading pump, TR-975, disassembled.

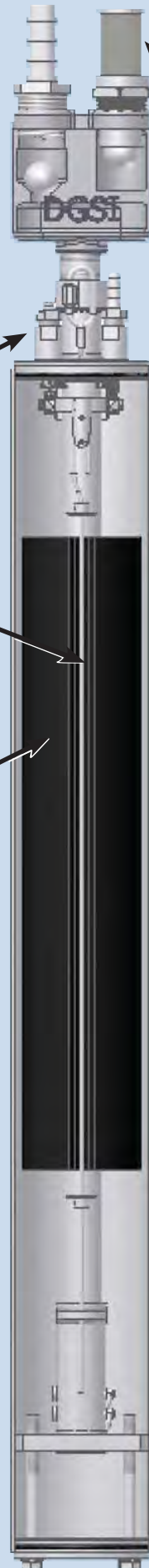

Ordering Information

Pump Construction

Stainless steel, Type 304:	Pump body, discharge tube
Stainless steel, Type 303:	Pump head, bottom intake valve, assembly control rod, control linkage assembly
Brass:	Hose and tubing bars
Hydlar (Nylon/Kevlar® composite):	Control rod bushing
Nylon®:	Discharge and top-loading check valve ball
Buna-N®:	Bottom intake check valve ball
Viton®:	O-ring seals, air inlet ball valve
Ebonite (expanded Buna-N®):	Float
Neodymium Iron:	Magnets
Red brass:	Top intake casting

2 inch SRX Pump Performance

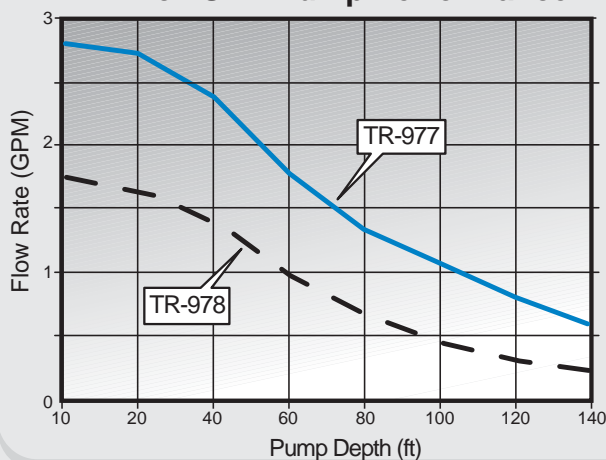

4 inch SRX Pump Performance

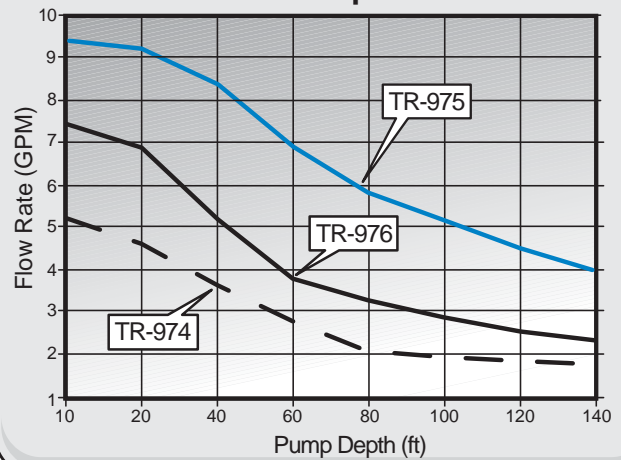

(Flow rates will be affected by the head above the pump as well as the length and I.D. of the air exhaust line.)

SELECTION TABLE FOR SRX REMEDIATION PUMPS

Part Number	Model ¹	Nominal Size (in)	Pump OD (in)	Pump Length (in)	Volume per Cycle ² (US gal)	Min. Submergence (in)	Pump Weight (lb)	Max. Flow Rate ³ (gpm)	Air Valve Filtration
TR-974	SRX-R TS (short)	4.0	3.5	39.0	0.2	39.0	16.6	5.5	Yes
TR-975	SRX-R BL	4.0	3.5	46.2	0.4	29.1	16.7	9.5	Yes
TR-976	SRX-R TL	4.0	3.5	44.5	0.4	44.5	18.0	7.6	Yes
TR-977	SRX-R BL	2.0	1.75	44.0	0.12	29.3	4.0	2.9	Yes*
TR-978	SRX-R TL	2.0	1.75	43.5	0.12	43.5	4.2	1.8	Yes*

¹ SRX-R TS = top-loading, short, SRX-R BL = bottom-loading, SRX-R TL = top-loading.

² Volume per pump cycle will vary slightly depending on air pressure supplied to pump, depth of well, etc.

³ Maximum flow rates can vary due to air pressure supplied to pump, depth of well, etc. For assistance, contact DGSi.

* SRX-R inlet filter only.



III 1 Gc
T6 Ta 1 °C to 100 °C

Accessories

Standard Hose Assembly

(TR-777 for 4-in pumps, TR-77701 for 2-in pumps)

Sold per foot.

Stainless steel suspension cable (918705). Sold per foot.

Cable clamps (602850).

TR-777 Standard Hose Assembly for 4-inch pumps				
Line	I.D. (in)	O.D. (in)	Pressure* (PSI)	Material
Air-in	.170	1/4	300	Nylon®
Air exhaust	3/8	5/8	250	Buna-N
Fluid discharge	3/4	1-1/16	250	Buna-N
TR-77701 Standard Hose Assembly for 2-inch pumps				
Line	I.D. (in)	O.D. (in)	Pressure* (PSI)	Material
Air-in	.170	1/4	300	Nylon®
Air exhaust	1/4	3/8	175	Nylon®
Fluid discharge	1/2	13/16	250	Buna-N

*Maximum Pressure @ 68 °F

Pulse Counter

(TR-77804 with fittings) (TR-77802 without fittings)

Used to determine the total flow of the SRX pump. The compact and robust counter is installed in the air supply line at the well head. As the pump cycles, the counter senses the drop in air pressure that indicates the pump has cycled. The number of cycles is multiplied by the internal volume of the specific pump you are using to calculate the flow rate. The counter body can be disassembled for cleaning.



TR-77804.

(R) Fittings kit supplied with TR-77804.

TR-77804	Pulse Counter (with fittings kit)	1 lb
TR-77802	Pulse Counter (without fittings)	1 lb
Materials	Delrin body and piston, 304 stainless steel spring, Nylon set screw, plated steel end fittings, Neodymium iron magnets (2) and polycarbonate counter	
Dimensions	1.5 in dia. x 4.75 in	

Filter/Regulator

(TR-77803)

Used to supply proper air pressure to the SRX pump and optimize air consumption. It should be installed at the well head and includes a 5-micron filter, various fittings and mounting brackets to meet most requirements.



TR-77803, Filter/Regulator.

(R) Fittings kit provided with TR-77803.

TR-77803	Filter/Regulator with Fittings Kit	2 lb
Range	0 - 125 psi (Max. 150 psi)	
Fittings	Brackets, tube and hose fittings are included for SRX installations and DGSI well seals. Some assembly required.	
Capacity	Less than 1 psi pressure drop while passing 20 scfm at 100 psig.	
603538	Particulate filter replacement	
Dimensions	10.3 in X 2.48 in	

Flow Valve

(TR-698)

Used when lower flow rates are required. Once installed on the exhaust line of an SRX series pump, the user will be able to restrict air exhaust to regulate the fill time of the pump. May be used with or without well clinchers.



TR-698

TR-698	Flow Valve	2 lb
Pressure	0 - 100 psi	
Size	3/8-in ID barbed fitting x 3/8-in npt fitting	

Optimize the SRX pump performance

The two primary factors that influence the flow rate of the SRX are the liquid or head above the pump and the ability to quickly remove the air from the pump. Exhausting the air is especially important on deeper installations where the air is vented to the surface. It may be necessary to increase the size of the exhaust line.

In other applications, it may be desirable to reduce the flow rate of the SRX pump. This is accomplished by restricting the rate at which the air is allowed to escape from the pump. The slower the air flows out, the slower the pump will fill. DGSI offers the flow control kit (TR-698) to adjust the fluid discharge rate.

Well Seals

DGSI well seals provide an easy method for connecting fluid and air lines to simplify installations. Strain relief seals isolate the individual DGSI tubing sizes used on the SRX pumps and are vacuum rated.

The well seals are attached to the casing, sealing them to the diameter of the well casing with a Fernco™-type flexible coupling. Additional threaded openings through the seals are provided for fluid level monitoring.

Eyehook included for attaching pump support cable.

Note: The Nylon Bundled Tubing Assembly, (TR-794) is not compatible with the well seals described on this page. If well seals are needed for your application, contact DGSI.



4-inch well seal, TR-27302

2-inch well seal, TR-27301

Well Seals Construction

Fernco-type seal:	Neoprene rubber, stainless steel hose clamps
Eyelet for pump construction:	Type 304 stainless steel
Compression seals for hoses and tubing:	Nylon® and neoprene rubber
Pipe plugs:	Nylon®
Hardware misc.:	18-8 stainless steel
Top seal plate:	Gray PVC

How to spec your well seal: Select part numbers from the following groups as needed.

TR-27301

2 in Well Seal Assembly
TR-27301

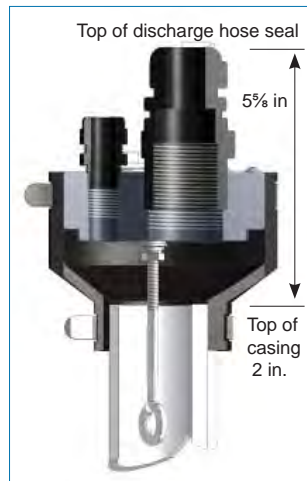

Cutaway illustration of TR-27301.

TR-27302

4 in Well Seal Assembly
TR-27302

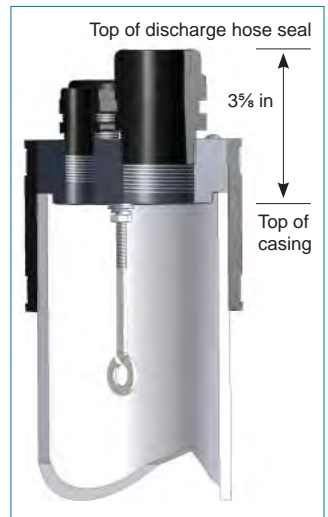

Cutaway illustration of TR-27302, TR-27303 and TR-27304.

TR-27303

6 in Well Seal Assembly
TR-27303

TR-27304

8 in Well Seal Assembly
TR-27304

Note: To view detailed information on the above listed parts, visit www.DGSI.info