

## Hose Barb Sizes



Exhaust Hose Barb  
3/8 in O.D. x 5/16 in I.D.  
Nylon Tube



Air Inlet 1/4 in O.D.  
Push-To-Connect  
1/4 in O.D. Nylon Tubing



Fluid Discharge  
1/2 in I.D. Hose Barb  
1/2 in Buna-N Hose

**Warning:** All tubing or hoses attached to the pump must be secured with an appropriately sized hose clamp.

## Additional Info.



The quick-link chain loop is for securing the pump to the restraining cable.

When calling for parts or service, please include the serial number of your pump.

Additional drawings and parts lists can be found at [www.DGSI.info](http://www.DGSI.info)

# SRX-R PUMPS

Models TR-978  
Quick Start Guide V1.0



## Unpacking and Preparation

To remove the pump, separate the packing tape and four staples from the sides of the box, then pull apart the two box halves.



**IMPORTANT!** You will need to first remove the internal packaging before the pump can be used. A tag will be attached to the pump alerting you of this.

### To remove the internal packaging:

1. Remove the two bolts from the bottom assembly using either a 1/2 in socket or adjustable wrench.



2. Remove the bottom assembly.



### Internal foam packaging



- Now remove the pump body by simultaneously twisting the valve assembly and pulling at the same time until the pump and the body easily separate.
- Once separated, remove the upper-and-lower protective foam packaging.

**Note:** This packaging is provided to protect both the float and control rod from damage during shipping. DGSi recommends that you save this packaging as well as the box for any future shipping requirements.

To reassemble the pump, follow the above steps in reverse order. When installing the bottom check-valve, it is recommended that you stand the pump upside-down on the discharge hose-barb, then tighten the two bolts to pull the O-ring seals into place.

Additional drawings and parts lists can be found at [www.DGSi.info](http://www.DGSi.info)

## Maintenance

To clean the internal components of the pump, remove the housing as outlined in steps 1 – 3 in Packing and Unpacking, then remove the cotter and clevis pins from the bottom assembly before sliding the “T” assembly from the center discharge tube.



The control rod and float can now be removed for cleaning. The float springs must first be removed from the float (see illustration below, #29). Remove the barbed fittings to clean the exhaust and air-inlet valves from any debris.



To reassemble the pump, follow the above steps in reverse order.

**Warning:** Any further disassembly should be carried out by DGSi.

Note: Some parts listed are sold only as a kit.

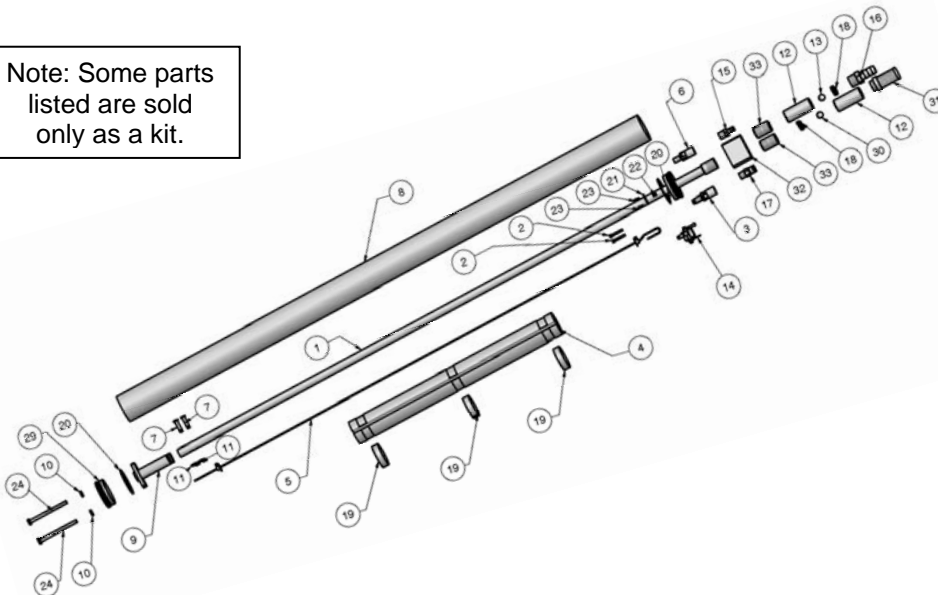

No.	Qty	Part #	Description
1	1	603095	Pump Head Weldment
2	2	603075	Cap Head Screw, 4-40 x 5/8"
3	1	603096	Air Valve Assembly
4	1	603092	Float Pump
5	1	603102	Control Rod Assembly
6	1	603069	Exhaust Valve Housing
7	2	603084	Clevis Pin 3/16"
8	1	603083	Pump Body
9	1	603081	Bottom "T" Weldment
10	3	603079	Seal Washer
11	2	603182	Hairpin Cotter Pin
12	2	603094	Check Valve Body
13	1	603268	Ball 3/8" Buna-N
14	1	603111	Air / Exhaust Valve Assembly
15	1	603266	Adaptor 1/8" MNPT x 1/4" Hose.
16	1	603272	Adaptor 1/2" Barb x 3/8" MNPT
17	1	301240	1/4" Tube Adaptor x 1/8" MNPT
18	2	603270	Retaining Ring Check Valve
19	2	603282	O-Ring Pump
20	2	602450	Magnet Cover
21	1	603071	Magnet, 3/16" Dia.
22	1	603086	Cap Head Screw, 2 x 56
23	2	603066	Bolt, 10-24 TPI x 2 1/2"
24	2	603289	Closed Bottom
29	1	603150	Nylon Ball, 3/8"
30	1	603269	Inlet Screen
31	1	603271	"Y" Top Fill Fitting
32	1	603148	3/8" Close Nipple, 304 S.S.
33	2	603267	